

SENATOR

MOTE

Mote has been designed to provide a holistic solution when designing dynamic environments. Created as a complete lounge seating range, no detail is an afterthought, with every inch having been given careful consideration to

eliminate dead space. The Mote family includes sofas, ottomans, screens and accessories, each linking seamlessly to each other to create a combination of rectilinear and curvilinear forms for beautiful yet defined spaces.



Design by Senator

FEATURES

Standard Features (*Selected models only)

- Traditional carcass construction with multi density foam
- Fully upholstered
- Cast Aluminium frame
- Plastic glides with levelling adjustment

Optional Features

- Frame fitted power units - 2 x powered
- USB/TUF and 1x power socket*
- Multiple fabrics
- End arms
- Single arms- mid
- Double arms - intermediate



DESIGN

Senator

Our team of talented in house designers are responsible for creating elegant, innovative furniture designs which not only look beautiful, but minimise the impact on the world around us.

They come from all over the world, but are based in our Design Centre located in a quiet Lancashire village just outside the Ribble Valley. Our dedicated facility is over three floors which include studios, a materials test centre and prototyping lab.

SENATOR

DIMENSIONS

Ottoman

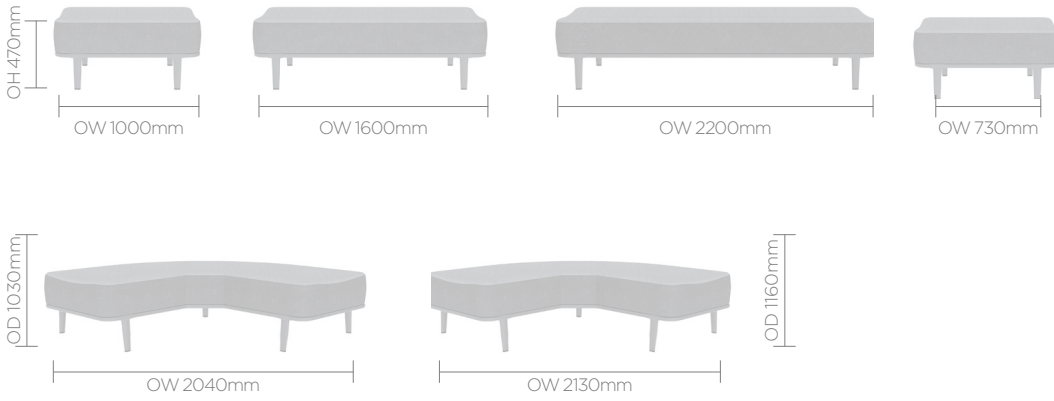

Sofa

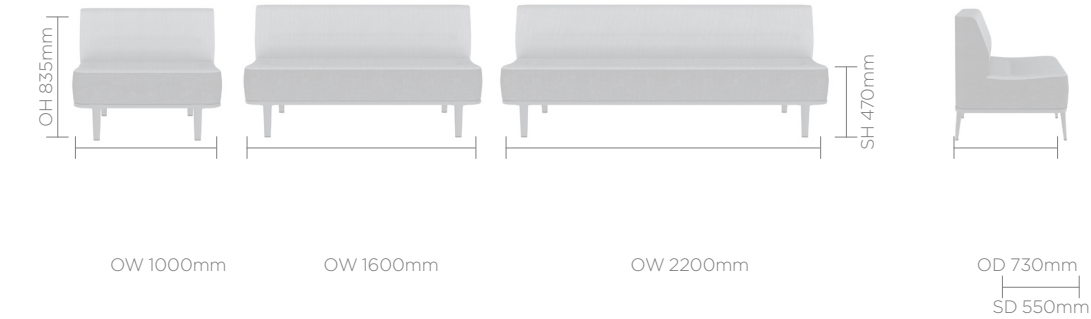

SENATOR

Rear Screen



Rear & Side Screen



SENATOR

Footstool

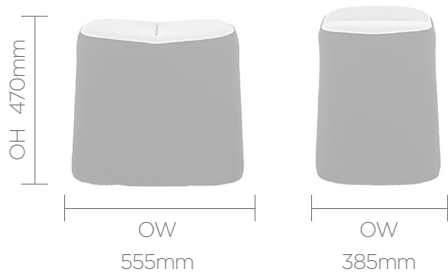

Bridging Screen

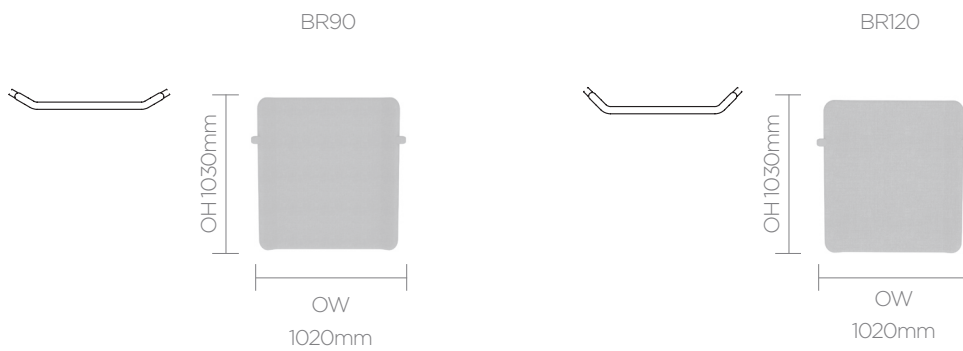

90° Two link unit

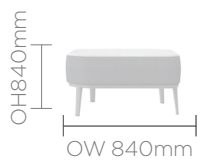

Finish Options

Cast Aluminium frame available in Black, Flint Grey, Light Grey or Mineral Sand, Mellow Yellow or Orange Crush

Frame Finishes



Black



Flint Grey

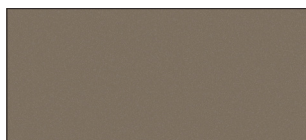

Mineral Sand



Mellow Yellow



Orange Crush

MFC Finishes

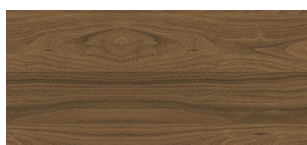

Carini Walnut

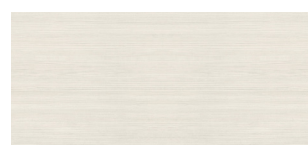

Hacienda White

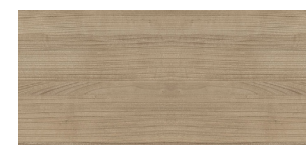

Autumn



Strata Oak



Maple

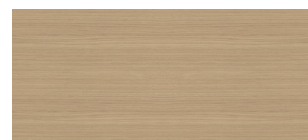

Highland Oak



Beech



Winter Oak

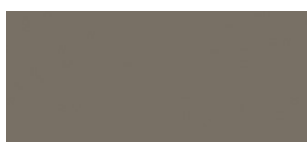

Clay

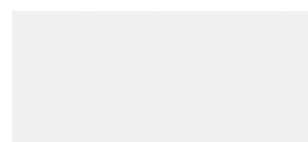

White



Light Grey



Denim

SENATOR

MOTE

Mote has been designed to provide a holistic solution when designing dynamic environments. Created as a complete lounge seating range, no detail is an afterthought, with every inch having been given careful consideration to

eliminate dead space. The Mote family includes sofas, ottomans, screens and accessories, each linking seamlessly to each other to create a combination of rectilinear and curvilinear forms for beautiful yet defined spaces.



Design by Senator

ENVIRONMENTAL

Material Content

Components are constructed of the following

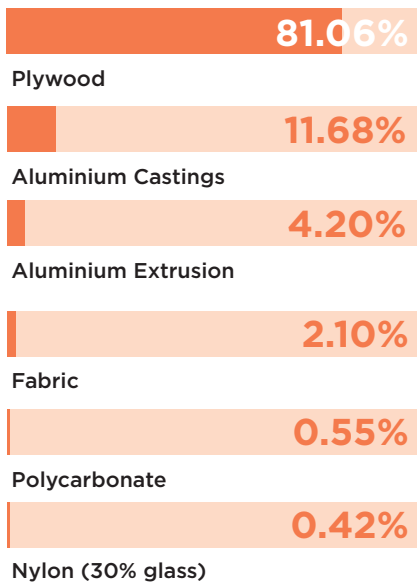

Recycled Content

Contains up to 17.00% of Recycled Material

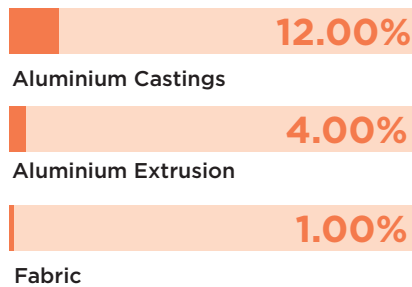

Recyclability

The range is 99% recyclable

99%

Environmental information for this range has been based on MTESF02.

SENATOR 3 R'S

Senator is committed to continually improving the sustainability of all environmental aspects within our business.

To meet both international standards and our own environmental targets we apply the three R's principle

-Reduce, Reuse and Recycle.

Whilst recycling is the element which receives the most exposure it is actually the last option available and should never be the prime target in anyone's battle to reduce waste.

It is our duty as individuals and as a company to initially attempt to **Reduce** usage. Then we should look to **Reuse** wherever possible and finally, only after these two processes have been exhausted, should we consider **Recycling**.

Reduce Reuse Recycle