

SENATOR

Array - ARC1606RC

In today's fast paced world, multi-use spaces have become a requirement of most organisations. People work, meet and collaborate all in the same location; Array has been designed with this in mind. Whether you're conferencing or training, Array is adapted so you can think, learn and work with ease.

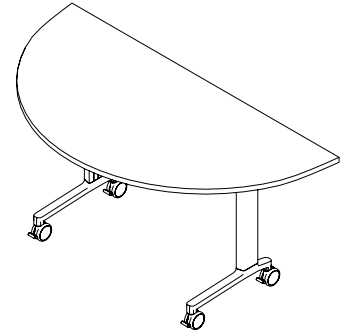

PRODUCT SUMMARY

Scope of Assessment:

From extraction of raw materials through to production of the final desking unit (cradle to gate).

See page 2 for more details.

Data Used:

Primary data was used wherever possible including for energy use during the core module.

All secondary data was obtained from the EcolInvent database, used in conjunction with SimaPro 7.3.2, using European data only.

Functional Unit:

A desking solution designed and manufactured to last for 15 years.

Regional Market:

The primary market for our Office Furniture products is Europe. The scope of this declaration reflects that.

ENVIRONMENTAL

Material Declaration Certificates

Material:	Amount (kg)	Total (%)
Aluminium castings	7.03	19.25
Aluminium extrusion	8.44	23.12
PU foam	0.10	0.26
Polypropylene	0.86	2.36
Steel	2.09	5.73
MFC	18.00	49.29

Environmental Summary

Global Warming Potential (Kg Co2 Eq):	33.81
Recycled Content (% By Weight):	67.05
Total Energy Consumption (Mj):	1079.77
Recyclability (% By Weight):	99.00

Date of Production: December 2021

ENVIRONMENTAL PRODUCT ANALYSIS

This Environmental Product Analysis has been created in accordance with, and following the principles of ISO14025 and ISO14044.

All the Life Cycle Analysis data has been compiled, processed and verified by Oakdene Hollins Ltd.



Compilation and processing of LCA data performed by Dr. Dan Skinner (Oakdene Hollins Ltd.)



Verification of LCA and environmental data performed by Dr. Adrian Chapman (Oakdene Hollins Ltd.)

SUSTAIN

The Senator Group has for many years acknowledged that the key word upon which to focus our attention is Sustainability rather than Recyclability in pure isolation.

Our business takes a truly holistic approach to the design, manufacture, supply and reclamation of our products. We see this as a cyclical process. From design to manufacture, use and reclamation we aspire to minimise all environmental impacts of The Senator Group's products and processes.

We harvest the resources back from the retired products then remanufacture or reintroduce the materials into our component manufacturers supply chain.

We believe in taking responsibility for our own actions ourselves, wherever possible, rather than relying on third parties, or abdicating our responsibilities by offsetting. The process of Sustainability is a cyclical one we understand this and we actively pursue this in everything that we do.

In Use:

No relevant environmental exchange occurs during the "in use" phase and is not considered in this Life Cycle Analysis.

End of Life:

End of life (recycling) is not considered in this Life Cycle Analysis however all of The Senator Group's products are considered to be 99% recyclable.

Group:

The Senator Group offers a full recycle service for all it's customers and clients, to close the recycling loop.

Upstream:

The upstream module of the product's life-cycle includes the extraction and treatment of raw materials, transport of the new material to the component suppliers and the manufacture of usable components from those materials.

Core:

The core module of the product's life-cycle includes the transport of furniture components to The Senator Group's plants and the energy resources used during product assembly/packing/loading and transport.

Downstream:

The Downstream module of the product's life-cycle includes transport of the product to The Senator Group's major market regions, using third transport vehicles.

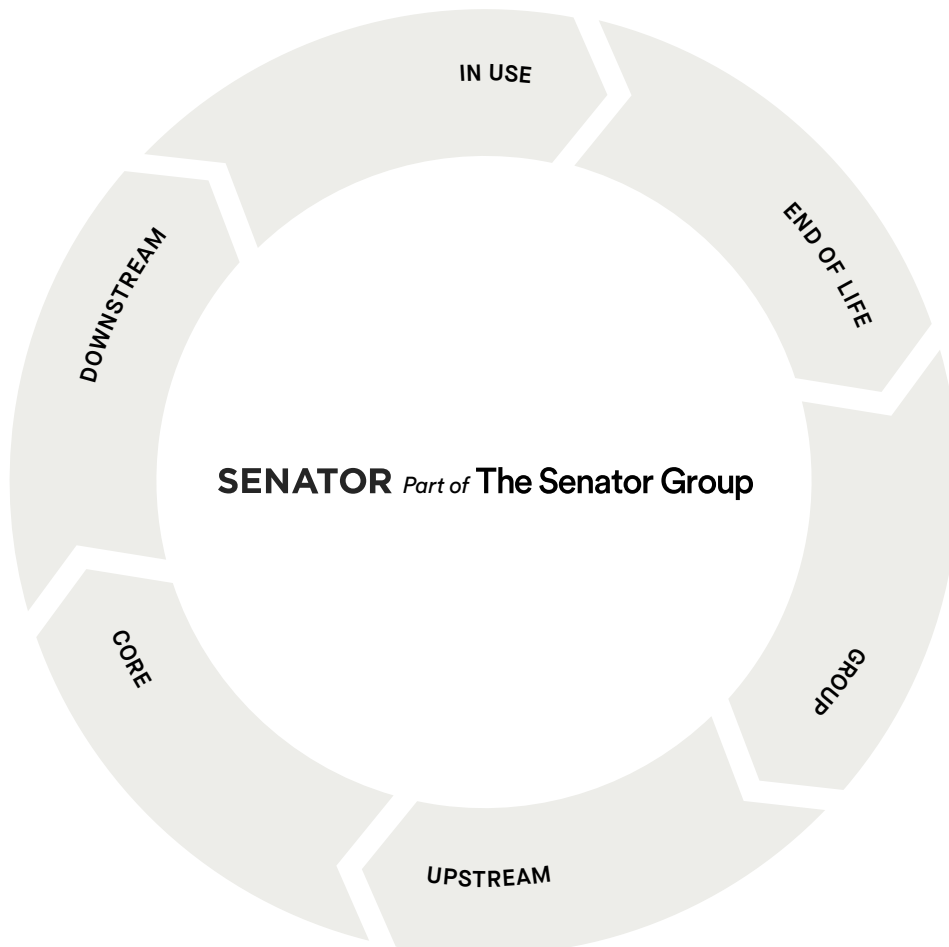

SYSTEM BOUNDARIES

Resource (Kg)	Upstream	Core	Downstream	Total
From the Air	32.03	1.00	0.00	33.03
From the Ground	14.32	14.52	1.32	30.16
From The Water	0.00	0.00	0.00	0.00

ENERGY CONSUMPTION

Resource (Kg)	Upstream	Core	Downstream	Total
Biomass	355.29	11.01	0.03	366.33
Hydro	18.52	3.31	0.16	21.99
Solar	0.02	0.00	0.00	0.02
Wind	1.51	1.06	0.01	2.58
Non-Renewable Energy (MJ)	493.56	179.81	15.48	688.85
Total	868.90	195.19	15.68	1079.77

ENVIRONMENTAL IMPACT POTENTIAL

Resource (Kg)	Upstream	Core	Downstream	Total
Global Warming (Kg CO2 Equivalents)	22.88	10.02	0.91	33.81
Acidification (Kg SO2 Equivalents)	0.10	0.04	0.00	0.14
Eutrophication (Kg PO43 Equivalents)	0.01	0.00	0.00	0.01
Ozone Depletion (Kg CFC 11 Equivalents)	0.00	0.00	0.00	0.00
Photochemical Smog (Kg C2H4 Equivalents)	0.01	0.00	0.00	0.01

TOXIC EMISSIONS

Resource (Kg)	Upstream	Core	Downstream	Total
To the Air	25.55	250.86	88.95	365.36
To the Ground	0.01	0.03	0.01	0.05
To The Water	2.95	4.60	1.32	8.88

ENERGY CONSUMPTION

Material	Recycled Content of Material (% by weight)	Recycled Content In Product (% by weight)
Aluminium castings	100.00	19.00
Aluminium extrusion	100.00	23.00
PU foam	0.00	0.00
Polypropylene	0.00	0.00
Steel	50.00	3.00
MFC	45.00	22.05
Total		67.05

CERTIFICATES

Description	Accreditation	First Certified
Quality Assurance	ISO 9001	Certified 1991
Environmental Management	ISO 14001	Certified 2001
Chain of Custody	FSC®	Certified 2003
Sustainability	FISP	Certified 2006
Occupational Health & Safety Management	ISO 45001	Certified 2021



All UK manufacturing Sites are accredited to ISO standards, 9001, 14001 and 45001. In addition to this Global Headquarters is certified to Chain of Custody. We can provide FSC® certified products upon request ISO

Furniture Industry Sustainability Programme:

Awarded by FIRA, this sustainability certificate is designed to monitor all sustainability aspects of a company's facilities and operations. The Senator Group achieved one of the first sustainability certifications within the furniture industry – a public declaration of our commitment to improving our performance in every possible way.

Chain of Custody:

Independent certification to prove Senator only purchases MFC/MDF/Chipboard from manufacturers who can prove they purchase their raw wood from sustainable sources.

Energy Management:

External proof that Senator has implemented a robust system to monitor all energy usage and have a process to continually minimise energy usage.

We believe Senator was the first company in the furniture industry to achieve this standard.

Environmental Management:

From extraction of raw materials through to production of the final Office Furniture unit (cradle to gate).

See page 2 for more details.

THE THREE R'S

Senator is committed to continually improving the sustainability of all environmental aspects within our business. To meet both international standards and our own environmental targets we apply the three R's principle – **Reduce, Reuse and Recycle**.

Whilst recycling is the element which receives the most exposure it is actually the last option available and should never be the prime target in anyone's battle to reduce waste.

It is our duty as individuals and as a company to initially attempt to **Reduce** usage. Then we should look to **Reuse** wherever possible and finally, only after these two processes have been exhausted, should we consider **Recycling**.

–Reduce
–Reuse
–Recycle

ASSESSMENT CONSIDERATIONS

The following necessary assumptions and considerations were made during the course of the Life-Cycle Analysis:

Manufacture of the furniture components was assumed to take place in the same factory in which the raw materials were processed, due to a lack of case-specific data.

The transport of all materials, components and finished products was assumed to be via 16-32t Euro 6 lorries.

All LCA data was modelled using the IMPACT 2002+ (v2.06) method.